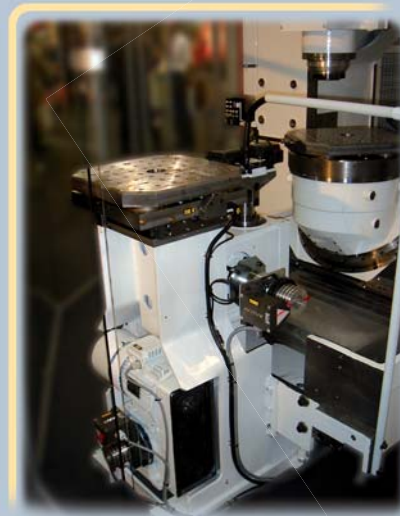
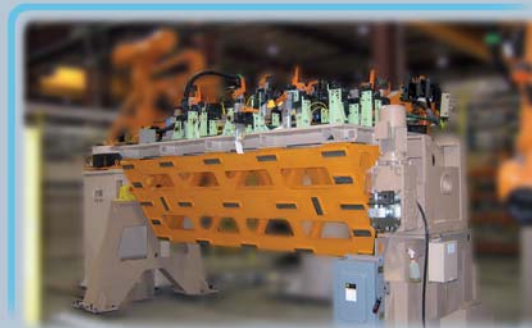

Table diameter : 1.8 Metre
Working load : 140 Tonnes



Handling system



Trunnion (automotive sector)



Stamping unit

NEW PRODUCTS FOR 2008



SOPAP

SOPAP LLC

1307 East Maple Road, Suite A - Troy, MI 48083

☎ +1 248 585 9327

☎ +33 (0) 3 26 69 21 31

✉ info-mi.usa@sopap.com

🌐 www.sopap.com

TS 2500

Drum cam driven indexing turntable.

The TS 2500 adds to and pushes back 'heavy series' boundaries.

This turntable has been designed for even larger and heavier applications, while retaining great accuracy.

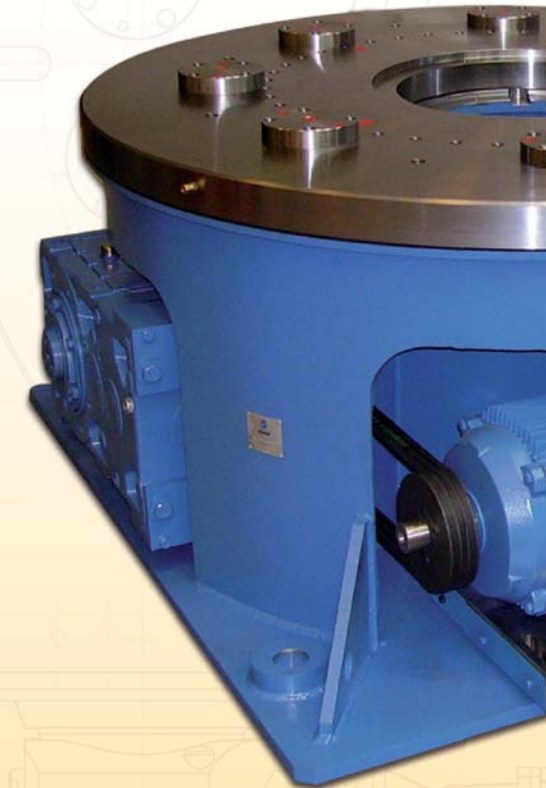

MI 200



Globoidal cam indexing turntable.

The MI 200 completes the MI 100 and MI 160 range. This turntable provides continuous or intermittent movement and generates large torque values at high speed. The mechanism can also feature a programmable version.

RING

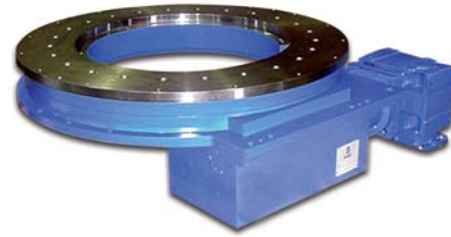

The drum cam indexing ring is a precision indexing mechanism that converts a continuous movement into an intermittent movement.

The mechanism can also feature a programmable version.

The extremely flat ring design with a large central passage provides the right conditions for circular transfer of assembly operations. The cam is located on the edge to improve the indexing precision.

Output ring :

Inner dia.	0 to 490 mm
Outer dia.	750 to 3000 mm
Material	Aluminium or Steel

TS 500 and TS 920

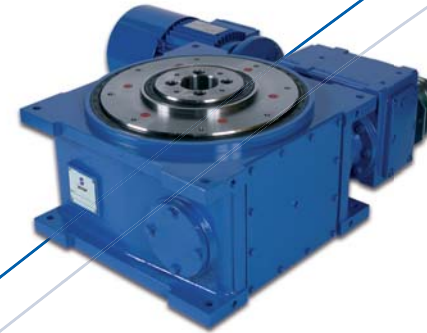

Drum cam driven indexing turntable.

Two new indexing turntables are now part of the TS range to be able to meet customer requirements as closely as possible by offering machines at the most attractive prices.



SOPAMAT Handling system

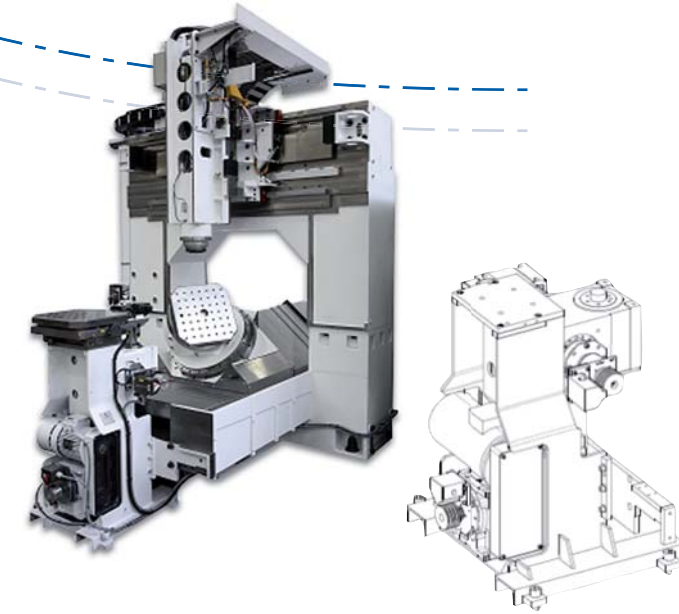

We can design and develop machines suitable for specific requirements. In this instance, we produce a handling system for machine tool with the following characteristics :

- Mass to move: 2 pallets with a unit mass of 250 kg
- Cycle time: 5 sec
- Cycle :
 - raise: 60 mm
 - rotation: 180°
 - lower: 60 mm

